



MAKING VEHICLES MORE EFFICIENT, ECONOMICAL
AND ENVIRONMENTALLY FRIENDLY



Zero Idling
Charging and
Heating System



PRODUCT CATALOGUE
NORTH AMERICA



Introduction

DEFA Line of Accessories	3
Zero Idling Charging and Heating Solutions	4
Business & Environmental Benefits	6
Introduction to the Kits	
Scalable Product Lineup	8
Opportunities and Benefits	9

Universal Application Chart

How to Choose the Right Assembly	10
Basic Kits	10
Comfort Kits	12
Comfort Smart Kits	13
WarmUp System	15

Products

Assemblies	
Cord Sets	16
Charger Assemblies	16
Cabin Heater Assemblies	17
Bluetooth® Upgrade Assemblies	18
WarmUp Assemblies	19
Single Parts / Replacement Parts	
SafeStart Engine Heaters	20
SafeStart Pump Kit	23
MultiCharger 1203X	24
Power Supply Cables	25
Power Cable Type Hanging Cord	25
Inlet Cables (Armored)	26
PlugIn Extension Cables (Armored)	26
PlugIn Branches and Contacts	27
Control / Programmable Units	29
Bulk Parts	
Bulk Boxes – Extension Cables	29
Bulk Boxes – Termini™ Cabin Heater Cable	29
Bulk Boxes – Single Cord Type Hanging Cord	29
Spare Parts / Mounting Equipment	
Cover/Pin/Spring Inlet Cable – 120V	30
Cover with strap Power Supply Cable – 120V	30
MiniPlug Mounting bracket for Plate Install	30
MiniPlug Mounting Kit with Discs	30
Workshop Equipment – Tools	
Pullwire and Installation tools	31
Workshop Equipment – Professional Chargers	
ShowRoomCharger 30A	32
WorkShopCharger 35A	33
Premium Look	
MiniPlug Installation Examples	34
Warranty	35

Information

DEFA North America Contacts	36
------------------------------------	----

DEFA Line of Accessories

For individual consumers or fleets of any size.

The DEFA Line of Accessories provides benefits to almost every vehicle on the road. From single passenger cars to industrial equipment and tractors, heavy duty trucks and large fleets.

The DEFA Line of Accessories will provide the following benefits to all drivers and fleet managers:

- Reliable engine starts even in extreme temperatures
- Fully charged batteries
- Warm comfortable cabins
- Reduced impact on the environment

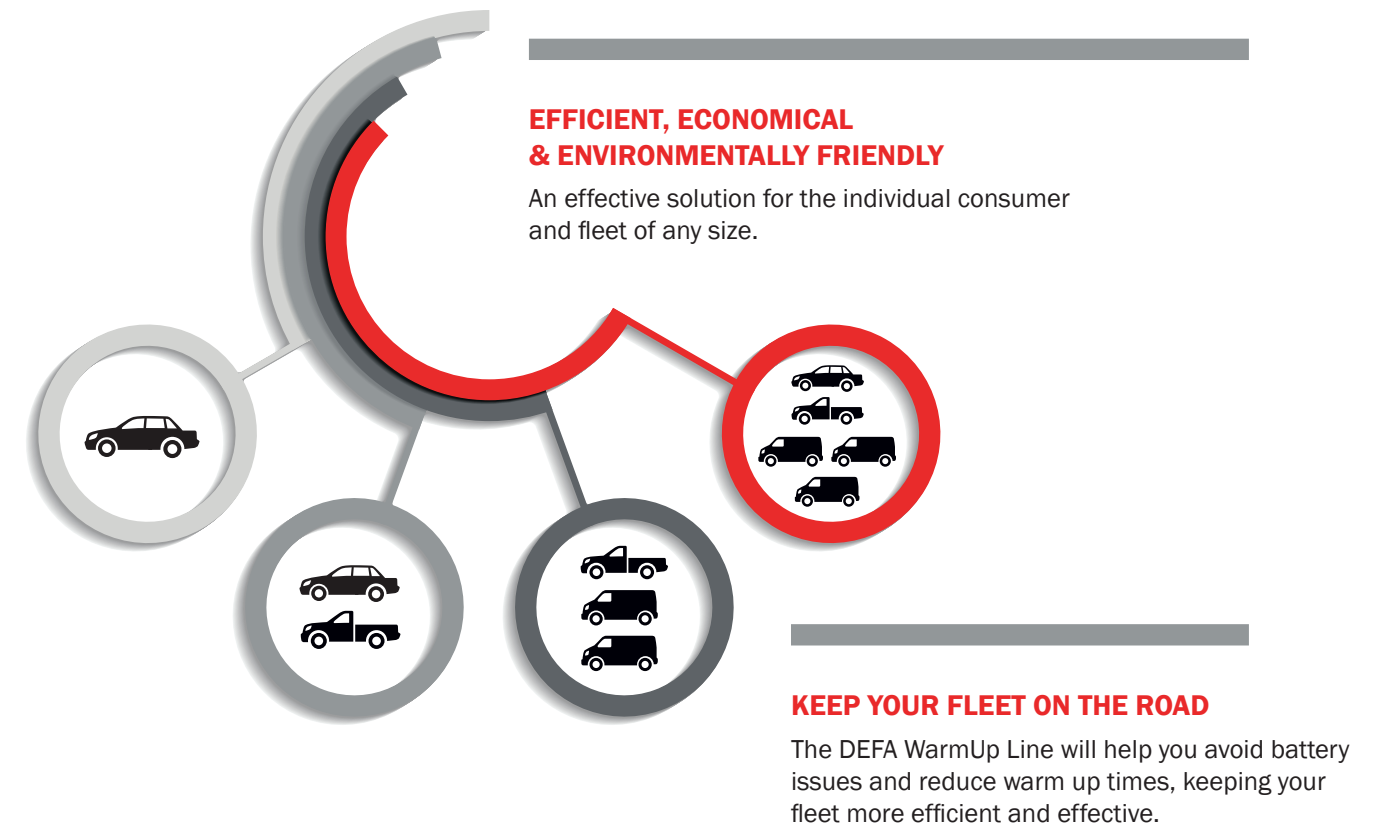

Zero Idling Charging and Heating Solutions

A complete solution for every vehicle.

CABIN HEATER

DEFA interior heater uses a PTC (PTC = Positive Temperature Coefficient) heating element which self adjusts the output power according to the inside temperature of the car. The PTC Ceramic element is extremely safe without open heating coils providing durability and safety as well as comfort and warmth.

ENGINE HEATER

Easy-to-start engine, less engine wear, reduced fuel consumption and a more environmentally friendly start to the day.



PROGRAMMABLE CONTROL UNITS

Both programmable control units will automatically start the system based on the outside temperature, ensuring that your car is always preheated in time and no excess energy is used.

BATTERY CHARGER

DEFA MultiCharger is a maintenance charger designed for modern battery technology that improves battery reliability and actually extends the battery's life span.

Zero Idling Charging and Heating Solutions

What is WarmUp?

The WarmUp system is an innovative Premium line of accessories. Directly engineered and tested in the Nordics, it offers more comfort, and reliability over the life time of the vehicle. This innovative package can also be completed with the use of one of the programmable control units or your smartphone to monitor and program the accessories. The line is made of 3 accessories that can be installed separately ("Basic kits") or in combination with each other. The 3 accessories are:

On-board SMART battery charger

Monitors and maintains battery at a healthy state of charge while preventing overcharging and sulfating.

Interior Cabin Heater

Smallest and most efficient heater in the world. It adjusts power usage based on cabin temperature (included in the Premium Kit).

Engine heater

Designed specifically for the engine and vehicle it is installed in, it increases effectiveness and ease of installation for dealer technicians. It also features heavy gauge ARMORED CABLE wiring harness for safety, and trademarked MiniPlug connector for appearance, safety and convenience.

Programmable Control Unit

A complimentary component of the Premium Kit, it is used in conjunction with the accessories above and is available either with an in-cabin control unit (Futura) or with a Bluetooth (Smartphone) connectivity. It allows you to separately control the heating system from the charging function and to program your heating system so your vehicle is ready when you need it, without wasting electricity or using fuel. The Bluetooth solution offers the convenience of connecting your smartphone device at no additional cost (no subscription is required).

Components are engineered to reduce environmental impact, eliminate idling* (compliant with anti-idling laws), and meet the highest level of quality, safety, and design.

* In order to function properly, DEFA WarmUp must be plugged into a functional, household 120V power outlet.

External laboratory. Test Center Tiiliä - Finland.



Consumer

Warmer interiors and more reliable engine starts.

A full line up of DEFA WarmUp Accessories are available to keep your customer warmer and on the road each morning. Whether they opt for the cabin comfort provided by the interior heater or the battery charging unit, they will enjoy a more reliable and environmentally friendly start to each day.

Business

Happy employees and customers.

Your vehicles will be ready to go when your employees arrive to work each day. Ensuring that they make the most of their day and yours, while delivering products or services to your customers. With the DEFA scalable lineup of WarmUp Accessories, you choose the level of comfort, reliability and savings, while providing an environmentally friendly vehicle.

Fleet

Keeping costs down and the fleet on the road.

Whether your fleet consists of a single vehicle, or hundreds or thousands, DEFA WarmUp Accessories will provide you with a more reliable and effective fleet for your operators and customers, while maintaining your commitment to the environment and reducing your overall operating costs.

Environment

DEFA WarmUp Accessories

More comfort*

The interior heater ensures the cabin is warmer and more comfortable in the middle of winter.

Reduced fuel consumption*

DEFA WarmUp heats up the engine and vehicle interior electrically, while ensuring the battery is fully charged before you start driving, all without using any fuel. A warmer engine starts and runs more efficiently. With a fully charged battery and a warmer interior, the demand for the defroster and seat heaters are reduced, along with the demand for the engine to power the alternator. All of these measures help to reduce fuel consumption.

Reduced harmful emissions*

A cold engine consumes more fuel and produces more harmful emissions. DEFA WarmUp contributes to significantly reduced harmful emissions.



Maximize battery performance*

DEFA WarmUp makes sure the battery is always charged. This makes the car easier to start on cold days. It also improves reliability and the life expectancy of your battery.

Reduced wear and tear on engine*

Use of an engine heater improves the lubrication properties of engine oil and therefore reduces the wear and tear caused by friction on your engine. It also enables your engine to start faster and more smoothly, again reducing wear and tear on other components used to start your engine.

* In order to function properly, DEFA WarmUp must be plugged into a functional, household 120V power outlet.

External laboratory. Test Center Tiiliä - Finland.



Comfort levels tailored to you

A scalable product lineup based on the desired level of comfort and technology.

CHOOSE YOUR LEVEL OF COMFORT

From the Basic kit to the most comprehensive one, this scalable product lineup allows you to select your preferred comfort level, while ensuring savings and reduction to emissions at every level.

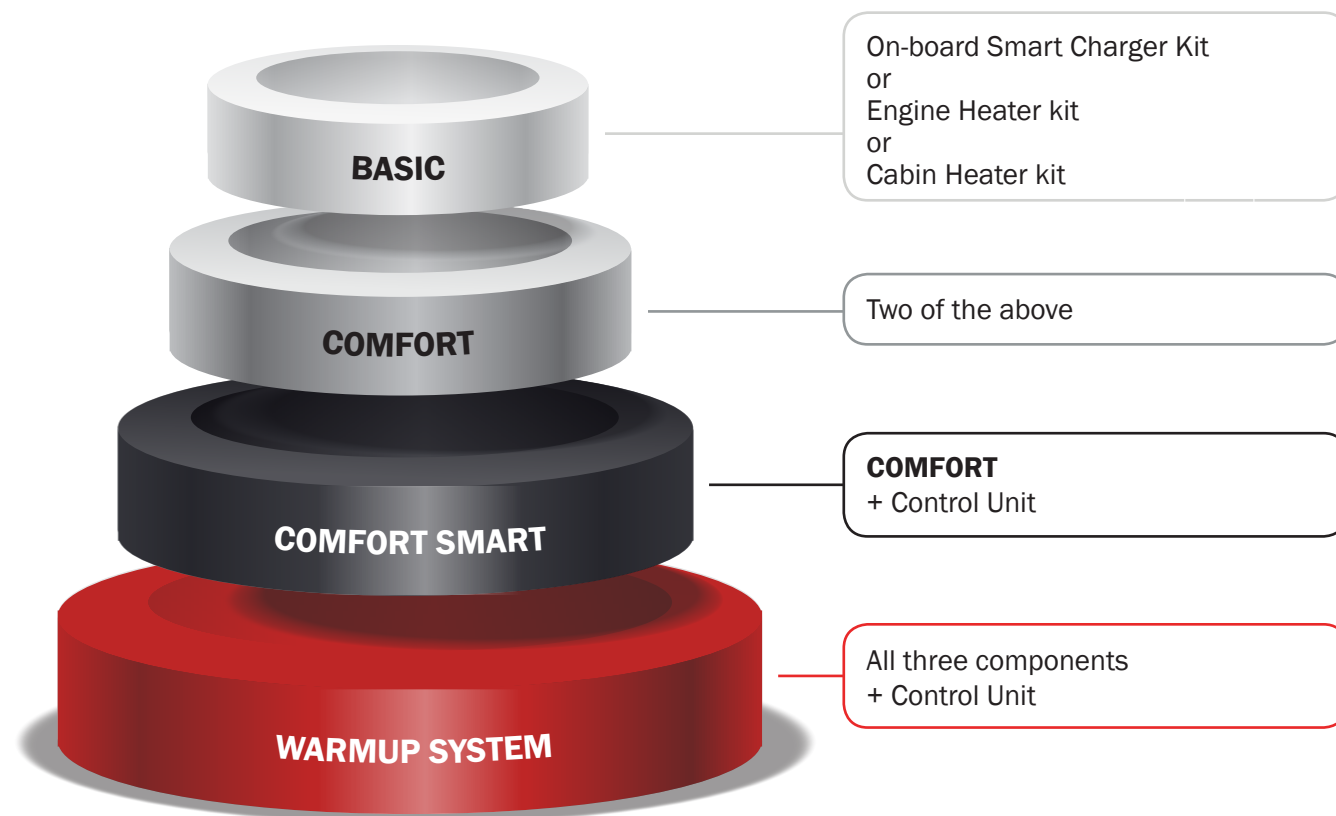

Makes your car happy

Opportunities and benefits

- Generate additional profit by offering a new and premium line of accessories.
- Expand consumer target group by offering an environmentally friendly system.
- Diversify your position from other competitors showing your commitment to a cleaner environment by offering a system that reduces greenhouse gas emissions.
- Increase customer satisfaction and loyalty by providing reliable and easy solutions to:
 - ▶ Reduce fuel consumption (zero idling).
 - ▶ Support vehicles with high electrical draw including those equipped with Remote Starter, Proximity Keys, Navigation, Tracking Systems, Electrical doors/tailgate, Rust Modules, etc.
 - ▶ Support battery reliability and longevity for drivers with low mileage driving habits, urban/short distances commuters, and people who park their vehicle for extended periods of time.
 - ▶ Ensure a warmer vehicle during cold weather without idling the engine.
 - ▶ Reduce engine and battery wear and tear, improve interior warmth and comfort.
 - ▶ Improve safety with the UL/CSA certified heavy duty power cord to power outlet, armored cables, proprietary MiniPlug connectors.
 - ▶ Premium look with its flush mounted MiniPlug (no more hanging cord).
 - ▶ Improve convenience by setting your pick-up time. The “auto-function” will adjust heating time based on the outside ambient temperature.
 - ▶ Cable alarm system to alert you if you have forgotten to unplug the cable when you start your vehicle (Bluetooth only).
 - ▶ Flexibility to program day/s of the week you need the system to function (Bluetooth only).
 - ▶ Optimize power usage. WarmUp automatically adjusts heating time, battery charging current and power usage based on temperature.

Educational videos:

- WarmUp System: <https://vimeo.com/82172439>
- WarmUp with Bluetooth® functionality: <https://vimeo.com/142857169>

Universal Application Chart

How to choose the right assembly

Just count the red boxes and select the assembly that fits your need.*

BASIC*

- On-board Smart Charger Kit
- Cabin Heater Kit
- Engine Heater Kit

COMFORT*

- Engine Heater + Charger
- Engine Heater + Cabin Heater with Y connector

COMFORT SMART*

- Charger + Engine Heater + Control unit
- Charger + Cabin Heater + Control unit
- Cabin Heater + Engine Heater + Control unit

WARMUP SYSTEM*

- Charger + Engine Heater + Cabin Heater + Control unit

BASIC Kits

On-board Smart Charger Kit

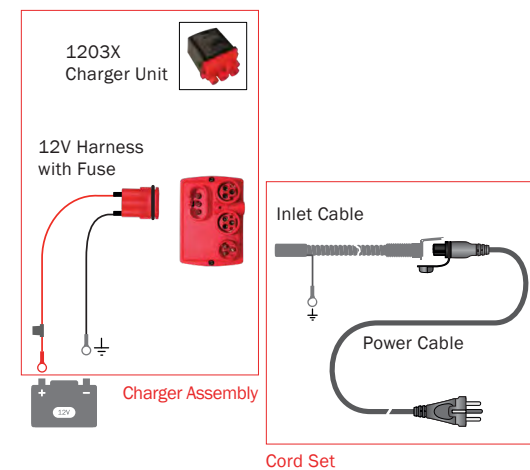

DEFA Smart Charger Assembly:

How to determine which charger Assembly to use:

Step 1: Find a suitable location within the engine compartment or inside the inner fender area where the charger unit will be installed keeping in mind:

- ▶ Charger must be installed in a vertical orientation (up to a 45-degree angle is allowable).

Step 2: Measure the length of the 12V wires harness between the charger and the battery connections keeping in mind:

- ▶ 12V harness must be secured away from hot and moving parts

The length of the 12V harness will determine which assembly to pick (2m/6.6ft, 2.6m/8.5ft or 3.5m/11.5ft).

DEFA Cord set:

How to determine which cord set to use:

Step 1: Find a suitable location where the PlugIn socket of the Inlet cable (called MiniPlug) will be installed keeping in mind:

- ▶ Consider a clearance of at least 12cm/4.7" from the front plug to the inside of bumper/grill (Inlet is an HD armored cable)

Step 2: Measure the length from the MiniPlug location to the Charger unit keeping in mind:

- ▶ Inlet cable must be secure to harness or frame of the vehicle to avoid contact with moving and/or hot parts.

The length of the inlet cable will determine which assembly to pick (0.8m/2.6ft, 1.5m/4.9ft, 2m/6.6ft or 3m/9.9ft).

Cabin Heater Kit

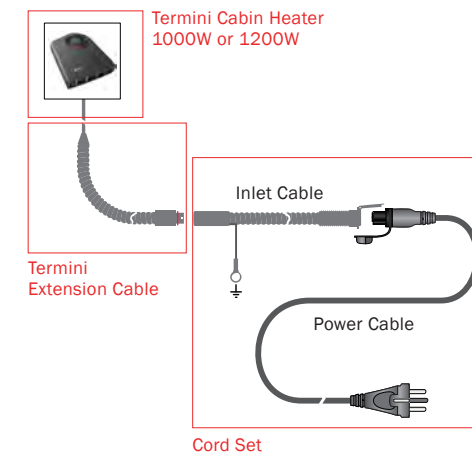

DEFA Termini™ Cabin Heater Assembly

How to determine which cabin heater power to use:

Step 1: Pick the level of power (1000W or 1200W) of the cabin heater keeping in mind:

- ▶ Total power load when you use other accessories. Never exceed 1650W/13.5A
- ▶ Volume to be heated

Step 2: Find a suitable location inside the cabin keeping in mind:

- ▶ Cabin heater must NOT be installed on driver side
- ▶ Best location is the passenger side of the center console or on the right kick panel at the bottom of the passenger side A pillar.
- ▶ The outlet of the cabin heater is pointing upwards towards the ceiling of the cabin.
- ▶ Some original wiring and components might be located behind interior trim panels.

Step 3: The Termini cable can be installed through any accessible rubber grommet in the firewall keeping in mind:

- ▶ Total length of this cable is 175cm/5.7ft of which: 100cm armored for hood compartment and 75cm/2.5ft not armored for cabin compartment

DEFA Cord set:

How to determine which cord set to use:

Step 1: Find a suitable location where the PlugIn socket of the Inlet cable (called MiniPlug) will be installed keeping in mind:

- ▶ Consider a clearance of at least 12cm/4.7" from the front plug to the inside of bumper/grill (Inlet is an HD armored cable)

Step 2: Measure the length from the MiniPlug location to the Termini Cable keeping in mind:

- ▶ Inlet cable must be secure to harness or frame of the vehicle to avoid contacts with moving and/or hot parts.

The length of the inlet cable will determine which assembly to pick (0.8m/2.6ft, 1.5m/4.9ft, 2m/6.6ft or 3m/9.9ft).

Engine Heater Kit

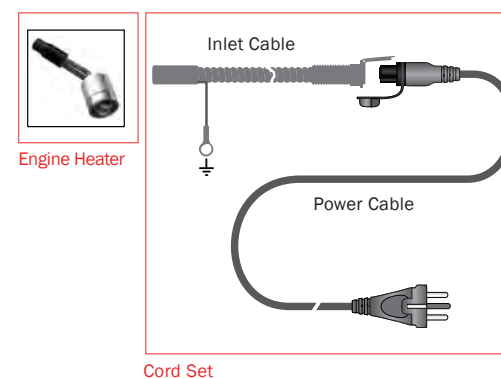

DEFA Premium Engine Heater Kit

How to find the right engine heater:

Please call 1-888-539-DEFA (3332) Ext 2 (for English) or Ext 3 (for French) to find out which heating element to order. DEFA engine heaters are custom tailored to the design requirements of each specific engine type. We offer a wide selection of engine heaters for many engine designs for North America.

DEFA Cord set:

How to determine which cord set to use:

Step 1: Find a suitable location where the PlugIn socket of the Inlet cable (called MiniPlug) will be installed keeping in mind:

- ▶ Consider a clearance of at least 12cm/4.7" from the front plug to the inside of bumper/grill (Inlet is an HD armored cable)

Step 2: Measure the length from the MiniPlug location to the heating element keeping in mind:

- ▶ Inlet cable must be secure to harness or frame of the vehicle to avoid contacts with moving and/or hot parts.

The length of the inlet cable will determine which assembly to pick (0.8m/2.6ft, 1.5m/4.9ft, 2m/6.6ft or 3m/9.9ft).

COMFORT Kits

Engine Heater + Charger kit

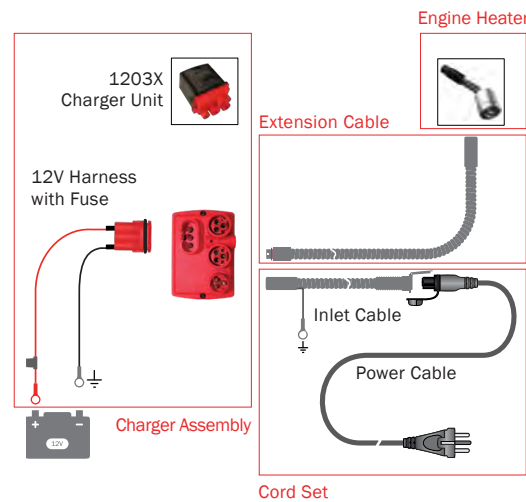

The SmartCharger kit and the engine heater kit can be combined keeping mind:

- Refer to the basic kits to pick the right assembly.
- You will need only 1 (one) Cord Set.
- You will need an Extension Cable.

How to determine the length of the Extension Cable:

Measure the length between the charger or relay or Y-connector (depending on configuration) and the other DEFA components, keeping in mind:

- ▶ The Extension cable is an armored cable and must be secured away from moving parts, hot areas, high voltage cable (in Hybrid vehicles) and brake lines.

This length will determine which cable to order (lengths starts from 0.5m/1.6ft to 3m/9.8ft in increments of 50cm/19.7inch)

NOTE: DEFA recommends upgrading to Comfort Smart, to prevent waste of energy and allows separate control of the Charging and Heating functionality.

COMFORT SMART Kits

DEFA COMFORT SMART and DEFA COMFORT SMART PLUS assemblies offer an intelligent means of controlling the heating products through the use of one of our DEFA programmable control systems.

When you combine multiple components, it is always recommended to have a control unit to:

- Control heating systems separately from charging
- Program your heating system
- Optimize energy usage

The control unit is available either with a wired In-Car Control or wireless control by using the Bluetooth transmitter to pair your smartphone and have everything under control with a flick of your thumb.

INSTALLATION TIPS

DEFA Bluetooth System allows you a faster installation while maintaining the appearance of your customer's vehicle with a factory look.

Any time you use a cabin heater, invest a few dollars to reduce installation time by purchasing a pull wire kit. Thanks to its special plug system that allows connection to the Termini cabin heater cable, making the installation of the cable through the firewall will be easier.

Please see the following diagrams to choose the right components by following the procedure explained in the basic kits.

Engine Heater + Cabin Heater kits with Y Connector

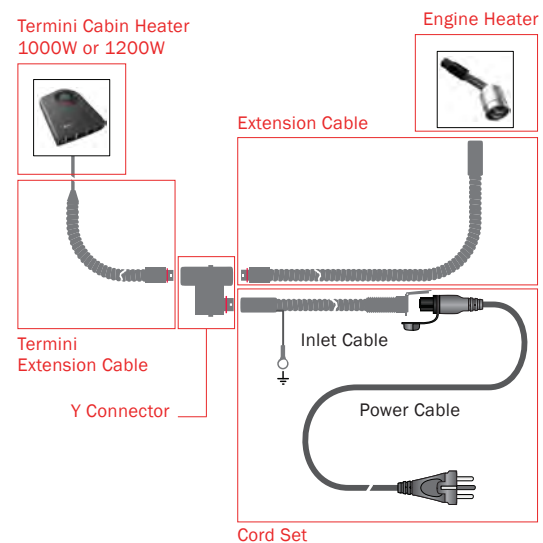

The SmartCharger kit and the engine heater kit can be combined keeping mind:

- Refer to the basic kits to pick the right assembly.
- You will need only 1 (one) Cord Set.
- You will need a Y Connector
- You might need an Extension cable to reach Termini cable

How to determine the length of the Extension Cable:

Measure the length between the charger or relay or Y-connector (depending on configuration) and the other DEFA components, keeping in mind:

- ▶ The Extension cable is an armored cable and must be secured away from moving parts, hot areas, high voltage cable (in Hybrid vehicles), brake lines.

This length will determine which cable to order to connect the heating element (lengths starts from 0.5m/1.6ft to 3m/9.8ft in increments of 50cm/19.7inch) and/or if you need the extra extension cable to power the cabin heater.

NOTE: DEFA recommends upgrading to Comfort Smart, to prevent waste of energy and allows separate control of the Charging and Heating functionality.

Charger + Engine Heater + Control Unit (Bluetooth Only)

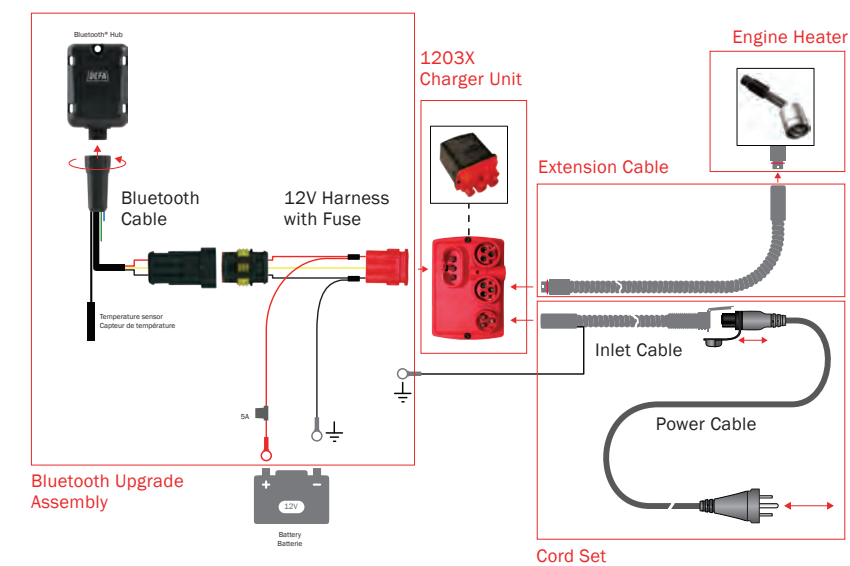

Cabin Heater + Charger + Control Unit

WITH BLUETOOTH® CONTROL UNIT

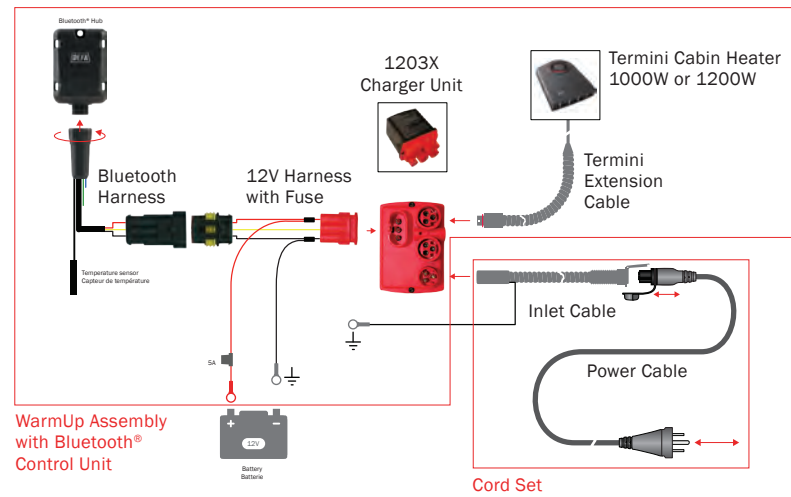

WITH FUTURA IN-CAR CONTROL UNIT

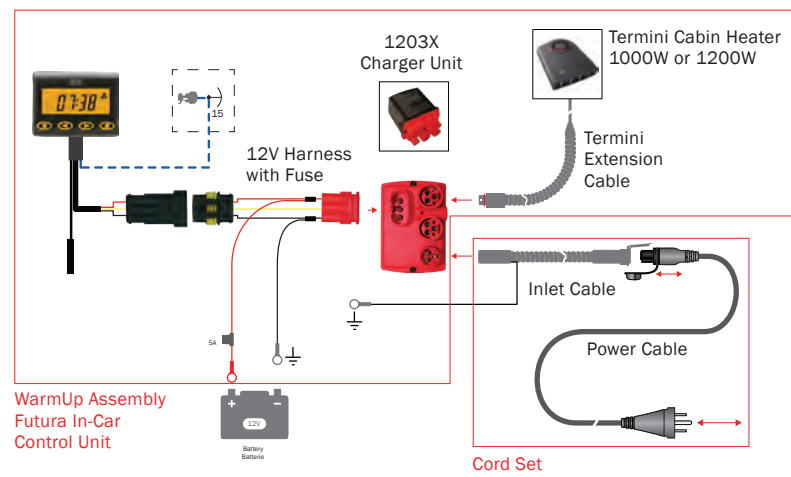

Cabin Heater + Engine Heater + Control Unit (Bluetooth Only)

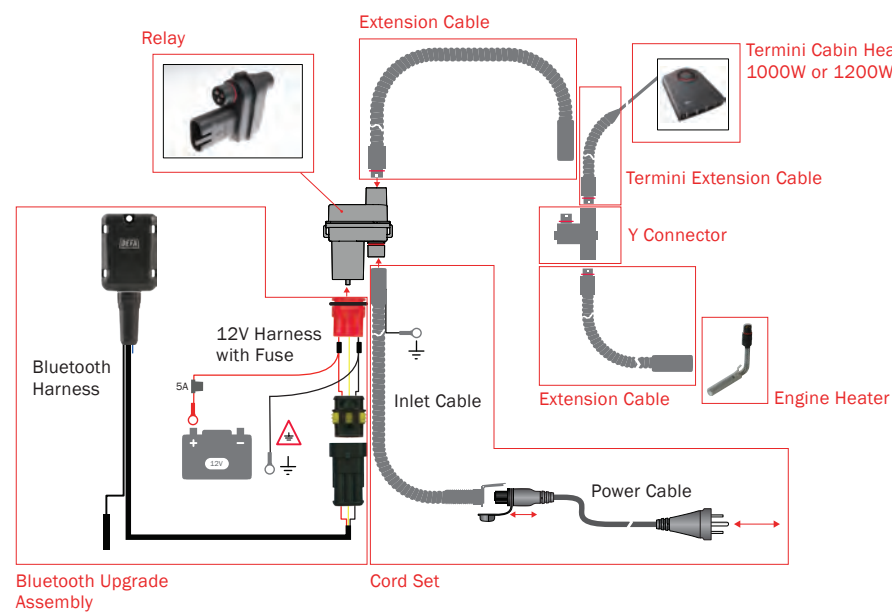

WarmUp System

Charger + Engine Heater + Cabin Heater + Control Unit

WITH BLUETOOTH® CONTROL UNIT

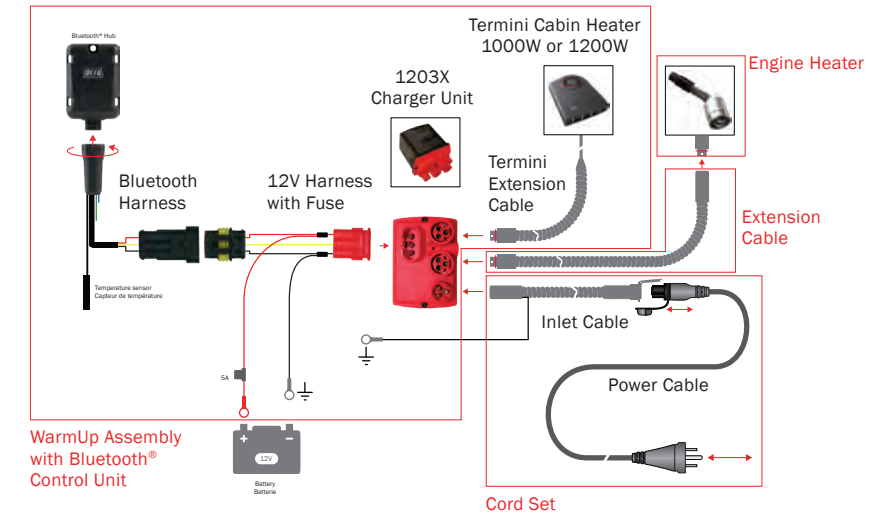

WITH FUTURA IN-CAR CONTROL UNIT

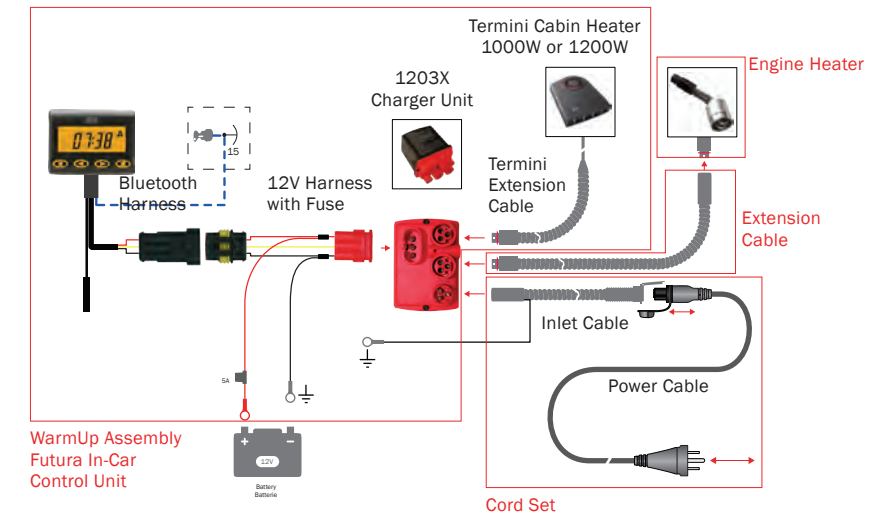

* The procedures reported in each diagram, are not actual installation instructions. Please contact DEFA for more information.

Assemblies

Cord Sets

Cord Set Assembly is designed to reduce the complexity of your inventory while increasing flexibility in applications. Cord Set comes with 3 mounting installation kits for the front MiniPlug (Bumper, Grill, Plastic fascia). A power cable rated SJOW to connect the system to a power outlet is also included to offer maximum quality, safety and durability.

For top performance it is recommended to clean the connector of the MiniPlug regularly by using an electrical spray cleaner and/or brake spray cleaner.



MiniPlug cord set

Inlet 0.8m/2.6ft + Power Cable 3.5m/11.5ft	460980
Inlet 1.5m/4.9ft + Power Cable 2.5m/8.2ft	463911
Inlet 2m/6.6ft + Power Cable 2.5m/8.2ft	463913
Inlet 3m/9.8ft + Power Cable 2.5m/8.2ft	463915
Voltage - VAC	120
Current, max - A	15
IP rate	44

Charger Assemblies

The charger assembly allows your business to reduce costs in components and storage while offering comprehensive vehicle coverage. For this reason we have made 3 assemblies where the difference is just the length of the 12V harness. All charger assemblies include rings of various diameters to fit most North American battery fitments.

DEFA pays a lot of attention to detail, for this reason we have also provided in this assembly an aluminum bracket for easy and long lasting installation, as well as foam patches to insulate the charger from any possible contact with hard parts that might generate vibrations and noise.



1203X On-Board Smart Charge with Harness, Mounting bracket and foam

Charger with 2m/6.6ft 12V Harness	453013
Charger with 2.6m/8.6ft 12V Harness	453014
Charger with 3.5m/11.4ft 12V Harness	453015
Voltage - VAC	120
Voltage - V / Charging current - A	3/12
Charging voltage boost mode - V	> 14.7

Assemblies

Cabin Heater Assemblies

DEFA interior heater uses a PTC (PTC = Positive Temperature Coefficient) heating element which self adjusts the output power according to the inside temperature of the car.

A 20°C/68°F temperature increase will result in a 10% power reduction. As the interior temperature increases the power will gradually be reduced accordingly. The interior heater is equipped with an automatic over-temperature protection. If the system stops, simply unplug the power for 20 minutes to allow the system to reset.

The interior heater is approved by: UL std. No. 2021 CSA std. C22.2 No. 46.



Termini™ 1000

Item No.	433101
Voltage - V	120
Rated power - W	1000
Power - W -25°C/-13°F	1000
Power - W +25°C/77°F	830
Height/Width/Depth - mm or inch	182/138/36 or 7.2/5.4/1.4"
Weight - gr/oz	600/21.2
IP rate	20



Termini™ 1200

Item No.	433103
Voltage - V	120
Rated power - W	1200
Power - W -25°C/-13°F	1200
Power - W +25°C/77°F	950
Height/Width/Depth - mm or inch	182/138/36 or 7.2/5.4/1.4"
Weight - gr/oz	600/21.2
IP rate	20



Termini™ extension Cable

Item No.	463391
Length - m/ft	1.75/5.7
Voltage - VAC	120
Current, max - A	15
Weight - gr/oz	250/8.8
IP rate	44

Assemblies

Bluetooth® Upgrade Assemblies

Designed to offer an upgrade solution to modern technology from the traditional in-Car control unit. Bluetooth Assembly is also a perfect choice when choosing to upgrade to a control unit. This assembly includes the Bluetooth hub and all harnesses to connect to DEFA 1203X On-Board Smart Charger or DEFA Relay for 1203X. Please contact DEFA North America if you have any question how to upgrade your DEFA Comfort kit.



Bluetooth® Upgrade kit for 1203X On-Board Smart Charger

Bluetooth Hub with 12V 2m/6.6ft Harness to Charger	443020
Bluetooth Hub with 12V 2.6m/8.6ft Harness to Charger	443021
Bluetooth Hub with 12V 3.5m/11.4ft Harness to Charger	443022
Voltage - VAC	8-32V DC
IP rate	IP6k9k

Assemblies

WarmUp Assemblies



Cabin Heater + On-Board Charger + Futura In-Car Control Unit

Cabin Heater 1000W with 12V 2m/6.6ft Harness	472013
Cabin Heater 1200W with 12V 2.6m/8.6ft Harness	472014
Cabin Heater 1200W with 12V 3.5m/11.4ft Harness	472911
Voltage - VAC	120
Current, max - A	15
Voltage - V / Charging current - A	3/12

Convenience and comfort at your fingertips

NOW YOU CAN GET THE COMFORT OF A DEFA WARMUP SYSTEM EASILY CONTROLLED BY YOUR SMARTPHONE.



Cabin Heater + On-Board Charger + Bluetooth Control Unit

Cabin Heater 1200W with 12V 2.6m/8.6ft Harness	472008
Voltage - VAC	120
Current, max - A	15
Voltage - V / Charging current - A	3/12

- Smartphone not included.
- Bluetooth Smart is available in the following operating systems:
 - ▶ iPhone 4s and newer
 - ▶ Android 4.4 and newer
- Deviations may occur. Use the DEFA app on the customer phone to check Bluetooth Smartphone compatibility.

Single Parts / Replacement Parts

SafeStart Engine Heaters

Easy-to-start engine, less engine wear, reduced fuel consumption and a more environmentally friendly start to the day.

DEFA SafeStart

A preheated engine starts easier, is exposed to less wear, gives reduced fuel consumption and up to 70% reduced harmful emissions until the engine reaches operating temperature. An electric engine heater is the most environmentally friendly way to preheat the engine.

If all cars had electric engine heaters, it would save the environment from large amounts of harmful emissions. The purpose with an engine heater is to create and transfer heat to the engine in an effective and best possible way. This can be done directly through heating the antifreeze fluid or oil, or indirectly through heating the engine block or oil pan utilizing a contact heater.

The DEFA engine preheater will raise the temperature of the engine up to 30-40 °C / 86-104 °F above the outside temperature, depending on where the heater is placed, type of heater and volume of antifreeze. The ideal connection time will depend on the outside temperature. After being connected for 3-4 hours in -15 °C/ 5 °F a thermal balance is achieved. This means any energy supplied afterwards only contributes to maintaining the temperature. The rest dissolves into the surroundings.

The engine heater can be connected for longer periods without either engine or heater being damaged. Though to avoid unnecessary power

consumption the Futura control unit has been designed to minimize electricity expenses by optimizing the heating time. In these instances it is best to use the Futura control unit in order to reduce electricity expenses.

DEFA offers several engine heater solutions whether the car is air- or water-cooled, and for large or small antifreeze volumes. We also have smart solutions for tractors, trucks and other engine vehicles and stationary engines. DEFA strives to find the optimal solution for each and every engine. There are DEFA engine preheaters with special flanges, engine preheaters for hose mounting or contact heaters. The main goal of all DEFA engine heaters is to preheat the engine optimally, regardless of fitting principals.

ENGINE HEATER IS CAR MAKE/MODEL SPECIFIC. ANY INSTALLATION OF ENGINE HEATER NOT RECOMMENDED BY DEFA, OR IMPROPERLY POSITIONED (ACCORDING TO THE INSTALLATION GUIDE), CAN RESULT IN THE ENGINE HEATER NOT FUNCTIONING AND THE ELECTRONICS OF THE ENGINE BEING EFFECTED.

Single Parts / Replacement Parts

SafeStart Engine Heaters

DEFA has focused on easy installation and optimal heating functionality during development of engine preheaters. For different engine and vehicle combinations DEFA has 9 primary heater elements with more than 500 variants and over 5000 individual applications.



SafeStart 0 - series

Characteristic	Flat conic flange
----------------	-------------------

The 000 - series can only be used on engine's with cast iron block. The heater's flange consists of a conical flange, and the heater is kept in place in the engines frost hole by a press fit solution.



SafeStart 100 - series

Characteristic	Conic cup flange
----------------	------------------

100 - series heaters are only used on vehicles with cast iron block. The heater's flange is formed as a cup in order to keep a small profile on the active heating area. The heater is used on engines with little space inside the water jacket.



SafeStart 200 - series

Characteristic	Threaded flange
----------------	-----------------

The flange of the 200 - series is threaded and is used on cars which have a threaded plug into the water jacket.



SafeStart 300 - series

Characteristic	T - or spread rail
----------------	--------------------

The heater is fastened to the engine block with a fixed spreader rail or a T - rail. The 300 - series is also used in areas where there is too little space around the element for press fit on cast iron block or in aluminium blocks.



Single Parts / Replacement Parts

SafeStart Engine Preheaters



SafeStart 400 - series

Characteristic	Hose heater without thermostat
Item No.	410400 - 410499

Number series from 420 to 423 are heaters with thermostat. The flange on this type of engine heater consists of a metal pipe. This pipe can encompass the whole or parts of the active element. The heater is attached to a specific point in one of the engines coolant hoses and is butted against a metal support (eg. water pump end pipe stub) With this method, the entire active part of the heating element is surrounded by metal.



SafeStart 500 - series

Characteristic	Special fastening point of the bracket
Item No.	410500 - 410599

Some engine types have hatches in different shapes which open to the water jacket of the engine block. This heater has a flange which is identical to the original hatch.



SafeStart 600 - series

Characteristic	Oil heater
Item No.	410600 - 410699

The oil heater is used on air cooled engines or in combination with engine heater for coolant.



SafeStart 700 - series

Characteristic	Hose heater
Item No.	410700 - 410799

These can be divided into two categories: Heaters without thermostat, number series from 701-709 and 758-799. Heaters with thermostat, number series 710-757.



SafeStart 715 - series

Characteristic	Hose heater
Item No.	410700 - 410799



SafeStart 800 - series

Characteristic	Footprint heater
Item No.	410800 - 410899

External contact heaters for aluminum engine blocks and oil sumps. The footprint heaters consist of an element cast in aluminium, adapted to the location of installation.

Single Parts / Replacement Parts

SafeStart Pump Kit



Pump kit

Item No. Kit	460908
Main Voltage	120V/12
Item No. Pump only	418920
Main Voltage	120V/12
Volume / hour at 0.1 bar / 1.45 psi	850 L/hr - 224.5 gal/hr

The Pump kit includes:

- 12V High Efficiency pump
- Power Supply with two outputs 12V and 120V to power the pump and the engine heater respectively
- 12V harness (1.7m / 5.6 ft length) to power the pump
- Assembly equipment

In order to improve the circulation of the coolant during the heating process, it might be necessary in certain circumstances to install an automatic circulation pump in addition to the heater.



Power Supply Kit

Item No.	452020
Main Voltage	120V/12
12V out, Max - A	2.0
12 Harness 1.7m/5.6ft only	418106
Height/Width/Depth - mm or inch	63 /92/37 or 2.48 /3.62/1.46 "
Weight - gr/oz	180/6.4
IP rate	65
Input voltage - VAC/Hz	120/50 - 60

This unit has a 120V input and two outputs:

- 120V power to engine heater
- 12V power to pump

Power Supply Kit also includes:

- Bracket for the unit
- 12V harness (1.7m / 5.6ft length) to power the pump)

Single Parts / Replacement Parts

MultiCharger 1203X

DEFA On-Board Smart Charger 1203X is designed for modern 12V battery technology (no Li-Ion), and actually extends the life span of the battery. This charger has an internal relay function to control the DEFA engine and interior heaters, and is primarily designed for passenger cars and light trucks.

With a temperature sensor and sophisticated software, 1203X offers a perfect charging curve in all climates and an automatic boost mode for charges up to 5A/14.7V, especially when it gets cold. The new body design of the charger offers high quality resistance to water and dust intrusion.



MultiCharger 1203X

Item No.	418991
Rated output - W	45
Voltage - V / Charging current - A	3/12
Charging voltage boost mode - V	> 14.7
Float voltage - VDC	13.7
Height/Width/Depth - mm or inch	80/70/45 or 3.1/2.8/1.8"
Weight - gr/oz	252/8.9
Fuse - A	5
IP rate	44

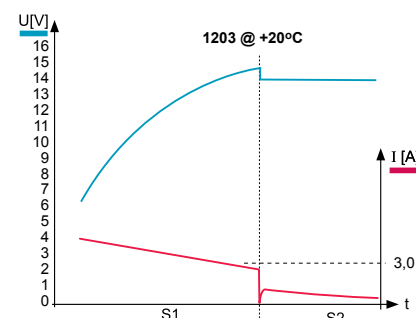
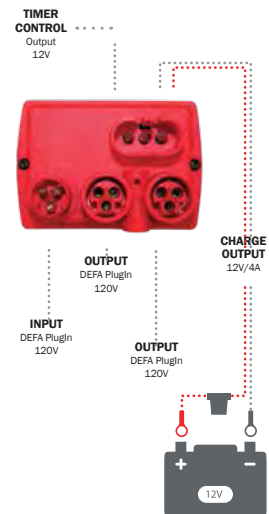

S1: Charging - Charges with 3A until voltage reaches 14.7V.
S2: Float voltage 13.7V.

Single Parts / Replacement Parts

Power Supply Cables

A secure connection from your power outlet to your vehicle, DEFA connection cables feature DEFA MiniPlug for a reliable and secure connection from power outlets to the car. DEFA Power Cables are engineered and tested to last and work in very severe conditions Thanks to DEFA technology and premium materials, DEFA power cable is rated SJOW (300V, Oil-Resistant Outer Jacket, Weather and Water Resistant for indoor and outdoor).

It is not recommended to extend the length of DEFA Power Cable with other extension cords. Non-DEFA cables might not be rated to offer a reliable and safe connection and may increase resistance that can generate heat and/or cause fires.



MiniPlug connection cables

Item No.	Length - m/ft	Weight - gr/oz
463101	2.5/8.2	420/14.8
463102	3.5/11.5	590/20.8
463103	5.0/16.4	840/29.6
463105	10.0/32.8	1680/59.3
Voltage - VAC	120	
Current, max. - A	15	
IP rate	44	

Protecting cup of the Female MiniPlug System is available as spare parts under DEFA #418947.

Power Cable Type Hanging Cord

DEFA Power Cable type hanging cord uses the DEFA PlugIn system to offer maximum safety and protection of the connectors. For this reason this type of cable solution is recommend for stationary unit and not designed to be connected and disconnected frequently. This will compromise durability and integrity while reducing insulation of the electrical prongs.

Its certification rating of SJOW allows you maximum safety and durability against oil and weather. Do not use this cord in proximity of hot surfaces and/or compartments such as the engine.

It is not recommended to extend the length of DEFA Power Cable with other extension cords. Non-DEFA cords may not be rated to offer a reliable and safe connection and they will increase resistance that can generate heat and/or cause fires.



Type Hanging Cord

Item No.	Length - m/ft	Weight - gr/oz
460937	2/6.6	276/9.7
460932	4/13.1	540/19 oz
Voltage - VAC	120	
Current, max. - A	13	
IP rate	44	

Single Parts / Replacement Parts

Inlet Cables (Armored)

During the development of DEFA MiniPlug we emphasized on a functional design, safety, optimal installation and user friendliness. DEFA Inlet cables are designed and certified to be used inside engine compartment with high temperatures. DEFA MiniPlug has a unique and trademarked design to reduce moisture accumulation within the plug.

Each Inlet Cable comes with 3 mounting installation kits of the front MiniPlug (Bumper, Grill, Plastic fascia).

For top performance it is recommended to clean the connectors of the MiniPlug regularly by using an electrical spray cleaner and/or brake spray cleaner.



MiniPlug inlet cables

Item No.	Length - m/ft	Weight - gr/oz
463211	1.5/4.9	535/18.9
463212	2.0/6.6	660/23.3
Voltage - VAC	120	
Current, max. - A	15	
IP rate	44	

The Inlet cable has a MiniPlug 'male-contact' with a protection cap on one end and DEFA PlugIn 'female-contact', in the other end. In addition it has a ground connector ion for the system. Protection cap is available as spare parts under DEFA #418946

PlugIn Extension Cables (Armored)

The components are easily connected together with DEFA's armored PlugIn extension cables. The system is designed to provide a reliable, tight connection and prevent incorrect connections. DEFA MiniPlug connection system prevents intrusion of dust and water offering a premium level of connectivity.



PlugIn extension cables

Item No.	Length - m/ft	Weight - gr/oz
463301	0.5/1.6	145/5.1
463302	1.0/3.3	265/9.3
463303	1.5/4.9	380/13.4
463304	2.0/6.6	497/17.5
463305	2.5/8.2	642/22.6
463306	3.0/9.8	713/25.2
Voltage - VAC	120	
Current, max - A	15	
IP rate	44	

Single Parts / Replacement Parts

PlugIn Branches and Contacts

The DEFA relay contact is designed for DEFA PlugIn system. It is the interface to connect a DEFA Control/Programmable unit; if you are not using the DEFA 1203X on-board charger (this has a built-in relay), but you still want to control/program your cabin and/or engine heater.

A Y-connector is required any time you need to split the 120V power so that 2 DEFA components can be operated simultaneously.



PlugIn relay

Item No. 12V	463432
Height/Width/Depth - mm or inch	90/33/67 or 3.5/1.3/2.6
Voltage - V	120
Current - A	15
Weight - gr/oz	59 / 2.1
IP rate	44



PlugIn Y-connector

Item No.	463401
Height/Width/Depth - mm or inch	53/48/24 or 2.1/1.9/0.9"
Voltage - V	120
Current, max - A	15
Weight - gr/oz	23 / 0.8
IP rate	44

DEFA Y-connector is an all-welded connector for connecting engine and interior heater or MultiCharger battery charger.

Single Parts / Replacement Parts

Control / Programmable Units

A complimentary component in the WarmUp Assembly, it is available either with an in-cabin control unit (Futura) or with a Bluetooth (Smartphone) connectivity. It allows you to separately control the heating system from the charging function and to program your heating system so your vehicle is ready when you need it, without wasting electricity or using fuel. The Bluetooth solution offers the convenience of connecting your smartphone device at no additional cost (no subscription is required). Above all it alerts you if you have forgotten to unplug the cable before you start driving (smartphone must be paired to the hub).



Bluetooth® Smartphone Programmable Control Unit

Operating temperature	-40 - +80 °C
Voltage - V	8 - 32VDC
Average current consumption - mA	2mA
Height/Width/Depth - mm	112/46/24
IP rate	IP6k9k
Frequency/Radio protocol	2,4GHz /Bluetooth Smart
Range	In and around the car
Weight, Bluetooth® Hub	35g
Weight, cables	150g
Operating Systems interface	Android 4.4+, iOS 4S+, Windows
Smartphone not included.	



In-Car Wired Futura® Programmable Control Unit

Voltage - V	12
Current consumption - mA	3.5
Height/Width/Depth - mm or inch	37/47/13 or 1.5/1.9/0.5"
Weight - gr/oz	19/0.7
Test and approval	CRF 47 Part 15: 2011 ANSI C63.4: 2003

Features	Bluetooth® Hub Control Unit	Futura® In-Car control unit
Auto heating time based on temperature	✓	✓
1 hour heating time	✓	✓
2 hour heating time	✓	✓
3 hour heating time	✓	✓
4 hour heating time	✓	✓
Nr. pick up time in 24 hrs	2	2
Program day of the week	✓	
Show next pick up time	✓	
Heating components ON/OFF	✓	✓
Battery voltage level monitoring	✓	✓
Indication of cable is connected or not*	✓	
Cable alarm*	✓	
Outside Temperature	✓	✓
Temperature warning**		✓

*Requires Bluetooth connection (see all disclaimers in the user manual).

**Blinking in display light if the temperature changes into the range of +4 °C to -4 °C.

Bulk Parts

Bulk Boxes – Extension Cables

The components are easily connected together with DEFA's armoured PlugIn extension cables. The system is designed to provide a reliable and tight connection and eliminates incorrect connections.



PlugIn extension cables – Bulk 15 pieces

Item No.	Length - m/ft	Weight - Kg / Lbs
463321	0.5/1.6	2.7/4.8
463322	1.0/3.3	3.9/8.7
463323	1.5/4.9	6.0/12.6
463324	2.0/6.6	7.4/16.4
463325	2.5/8.2	9.6/21.2
463326	3.0/9.8	10.7/23.6
No. of pcs.	15	
Voltage - VAC	120	
Current, max - A	15	
IP rate	44	

Bulk Boxes – Termini™ Cabin Heater Cable



Termini™ extension Cable - Bulk 15 pieces

Item No.	Length - m/ft	Weight - Kg / Lbs
463395	1.75/5.7	3.7/8.3
No. of pcs.	15	
Voltage - VAC	120	
Current, max - A	15	
Weight - Kg / Lbs	3.7/8.3	
IP rate	44	

Bulk Boxes – Single Cord Type Hanging Cord



Type Hanging Cord - Bulk 15 pieces

Item No.	Length - m/ft	Weight - Kg / Lbs
463921	2/6.6	4.1/9.1
463922	4/13.1	8.1/17.8
No. of pcs.	15	
Voltage - VAC	120	
Current, max. - A	13	
IP rate	44	

Spare Parts / Mounting Equipment

Cover/Pin/Spring Inlet Cable – 120V



Cover/Pin/Spring Inlet Cable

Item No.	418946
----------	--------

Cover with Strap Power Supply Cable – 120V



Cover with strap Power Supply Cable

Item No.	418947
----------	--------

MiniPlug Mounting Bracket for Plate Install



MiniPlug Mounting Bracket for Plate

Item No.	463037
----------	--------

MiniPlug Mounting Kit with Discs



MiniPlug Mounting Equipment Kit with Discs

Item No.	705670
----------	--------

Workshop Equipment – Tools

Pullwire and Installation Tools

Tools for installation of MiniPlug and for installation of cables through the fire wall.



Pullwire kit – 3 pieces same application

Item No.	460864
----------	--------

No. of pcs.	3
-------------	---

Tool for easier installation of DEFA Termini™ extension cable through the fire wall. 3 equal.



Pullwire kit – 3 pieces different applications

Item No.	460866
----------	--------

No. of pcs.	3
-------------	---

Tool for easier installation through fire wall of DEFA Cables type Extension cable male and female as well as Termini Cabin Heater Cable. Delivered with 2 extensions of 1m/3.3ft.



Installation tool

Item No.	460841
----------	--------

Hole saw Ø24mm	For MiniPlug inlet cable
----------------	--------------------------

Hole saw Ø20mm	For Interior heater cable
----------------	---------------------------

File	For MiniPlug feed track
------	-------------------------

Hole saw retainer	With pilot hole drill
-------------------	-----------------------

High quality tools to drill bumpers, firewalls

Workshop Equipment – Professional Chargers

ShowRoomCharger 30A

Discrete, powerful, silent. Enhance customer experience by ensuring a fully functional vehicle in your show room, while protecting your battery at the same time.

Keep your vehicles fully charged and your showroom looking good with DEFA ShowRoomCharger 30A. The charger is designed using modern switch-mode technology and galvanic isolation. It has a 95% efficiency and uses a 7-step charging cycle that optimizes the performance and durability of the battery. The software can easily be upgraded via a separate USB port.

With its detachable DC cable that can easily fit through the engine compartment and reach down to the floor, you can keep the charger hidden. The ShowRoomCharger 30A has no fan which makes it completely silent. Its rubber feet and corners are designed to protect your vehicles and the showroom floor.



ShowRoomCharger 30A

Item No.	707373
Input voltage [VAC]	100-240 (@ 50-60Hz)
Operating temperature [°C]	-20/40
Charging voltage S1 [VDC]	14,4
Maintenance charging S2 [VDC]	13,6
DC power leads	2.5m / 8.2ft
AC Power Cord	5m / 16.4ft
Charging current [A]	30
Battery size, max [Ah]	500
IP rating [IP]	20
Height/Width/Depth - mm or inch	227/125/62mm or 8.9/4.9/2.4"
Weight Kg/Lbs	1.7/3.75
Certifications	UL1012, FCC part 15



Workshop Equipment – Professional Chargers

WorkShopCharger 35A

Portable, durable, user-friendly. Upgrade your work shop with the “all in one” automated charger and power supply unit that is the size of a book.

The DEFA WorkShopCharger 35A is a powerful charger for most types of batteries. It can be used as a battery charger for all 12V WET, MF, Ca/Ca, AGM, EFB and GEL batteries.

When you need continuous current and stable voltage during ECU Programming and/or battery change, the DEFA WorkShopCharger 35A can be used as a power supply.

Thanks to its technology, it is designed to easily and safely charge and maintain battery size up to 600Ah.

With its multiple sensors that measure battery temperature, it will define the optimal charging curve to maximize battery charge and performance.



WorkShopCharger 35A

Item No.	707200
Input voltage [VAC] 100-240 (@ 50-60Hz)	100-240 (@ 50-60Hz)
Operating temperature [°C]	-20/+50
Charging voltage S1 [VDC]	14,4/14,7
Maintenance charging S2 [VDC]	13,6
DC power leads	3m/9.8ft
Charging current [A]	35
Battery size, max [Ah]	600
IP rating [IP]	20
Height/Width/Depth - mm or inch	234x98x53mm or 9.2/3.9/2.1"
Weight Kg/Lbs	2.5/5.5
Certifications	UL1012, FCC part 15



Premium Look

MiniPlug Installation

Bumper Install



Grill Install



Plastic Fascia Install



Plate Bracket install



Rear Bumper Install



Easy and Precise Plug in System**

- Locate the MiniPlug socket on your vehicle's bumper and open the cap.
- Remove the protective cap from the MiniPlug on the power supply cable.
- Firmly insert the MiniPlug fully into the MiniPlug socket.
- The PlugIn system has been specially designed so you do not need to 'force' the connection.
- Plug the other end of the power supply cable into a wall socket outlet.
- To disconnect the power supply cable on the vehicle, hold firmly and gently pull the MiniPlug from the MiniPlug socket.
- Never disconnect by pulling the cable.

*In order to function, WarmUp must be plugged into a functional, household 120V power outlet.

**Please check total load of the system before plugging in other accessories into the same electrical outlet.

Warranty

DEFA Warrants to the original purchaser that all DEFA products supplied by DEFA, either directly or through a DEFA approved Distributor/Dealer will be free from defects in materials and workmanship for a Period of two (2) years from Sale and/or Installation. In all Customer claims cases, Sales receipts and/or installation work orders are required as evidence and must accompany the product when returned to the location of purchase.

For Customer claims reported during the warranty period DEFA will, subject to the DEFA SCNA technical analysis & sole determination, ensure that product found to be defective, will be repaired, replaced or refunded.

DEFA will have no obligation under this warranty period to repair, replace or refund any DEFA products claimed to be defective, if:

- The DEFA products have been used in connection with other third- party products and equipment.
- There has been incorrect or incomplete installation of the DEFA products.
- There has been improper or irresponsible use of the DEFA products.
- Modification or repair of DEFA products has been performed or attempted by anyone other than DEFA, without prior written permission from DEFA.

DEFA has no other warranty than this and will not be responsible for any other additional costs, neither is DEFA bound by any other warranty.

